

HydroTap Cube Plus CS Tap

Product Spec Sheet



HydroTap Cube Plus Chilled/Sparkling (CS) Tap

Elevate your home hydration with the HydroTap Cube Plus CS Tap and enjoy instant access to filtered chilled and sparkling water from the tap.

The HydroTap Cube Plus offers a contemporary twist on a classic with its angular square shape which is softened by its rounded corners.

This tap style can be installed over the sink as a secondary tap or over our optional design range front/drip tray. The HydroTap Cube Plus tap is available in six different finishes from a classic chrome to a modern gunmetal.

HydroTap Cube Plus CS Tap - Available Finishes



Chrome



Brushed
Chrome



Matte
Black

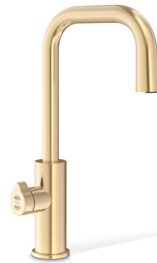

Brushed
Gold



Brushed
Nickel



Gunmetal

Product Order Codes for HydroTap Cube Plus CS Taps

HydroTap Cube Plus CS Tap in Chrome	01046230
HydroTap Cube Plus CS Tap in Brushed Chrome	01046231
HydroTap Cube Plus CS Tap in Matte Black	01046232
HydroTap Cube Plus CS Tap in Brushed Gold	01046233
HydroTap Cube Plus CS Tap in Brushed Nickel	01046234
HydroTap Cube Plus CS Tap in Gunmetal	01046235

Please see individual product spec sheets for command center and accessory product specs and order codes.

HydroTap Cube Plus CS Tap

Product Spec Sheet



Installation Requirements

The HydroTap is a pump-driven system so the installation of the Tap must be within 3' (0.9m) of the base command center. Installation on most countertops is straightforward however, some stone countertops may require a specialized cutting service.

If using a drip tray (font) accessory, suitable drainage to a trapped waste is required within 3' (0.9m) of the installation. Sufficient space and clearance to install the HydroTap as detailed in the product installation guidelines is required.

Installation and connection of your HydroTap must be carried out by a qualified person, observing all local, state, & federal regulations.

HydroTap Cube Plus CS - Tap Specs

Style:	HydroTap Cube Plus Tap (CS)
Hole Size:	1 - 3/8" / 35mm
Tap Height:	13.7" (349mm) fixed height from counter to apex of spout
Handle Orientation:	Left side - fixed
Installation:	The tap is showcased at its finest when paired with the optional Design Range Drip Tray / Drain Font. It can be also be installed as an accessory tap over an existing sink.
Flow Rate:	Max 1.8 gpm / 6.8 lpm
Sparkling Water Flow Rate	0.4 gpm / 1.51 lpm
Product Certifications:	IAPMO - NSF/ANSI 372, 42, 53, CSA B4438.1, ASSE 1087; cUL; CEC; AB-100
ADA Compliant:	Yes

Cube Plus - Front View

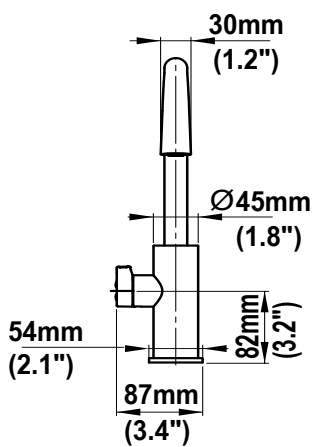

Cube Plus - Side View

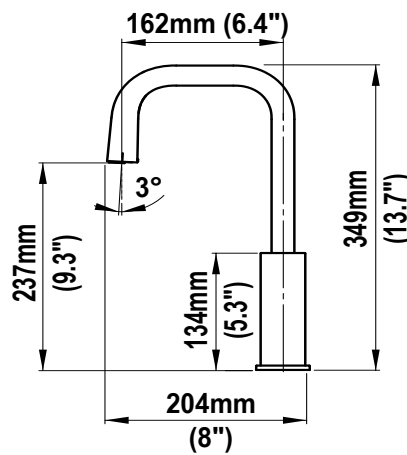

Cube Plus on Optional Standalone Font

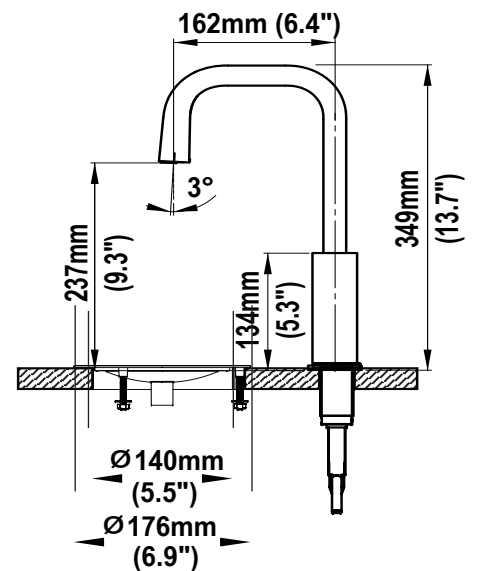

HydroTap 120V CS G5 Command Center

Product Spec Sheet

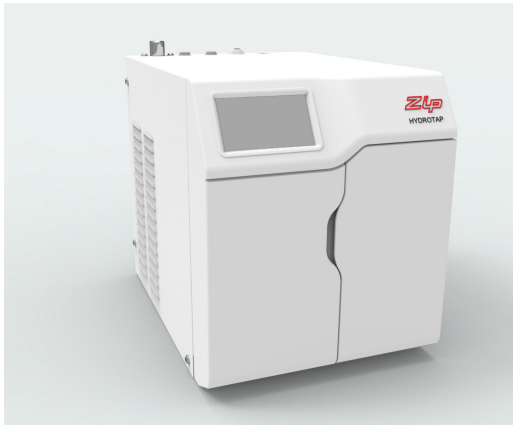

HydroTap 120V CS G5 Command Center

Product Order Code: 01043467

The HydroTap by Zip Water is sparkling water on-demand and it's water at its best. That's because the HydroTap 120V CS command center provides users instant access to filtered chilled still and chilled sparkling water.

This command center is ideal for residential and small commercial applications and can be paired with any of our various tap styles.

HydroTap 120V CS G5 Command Center - Product Specs

Product Order Code	01043467
Application:	For home or small office (up to 10 users)
Water Pressure:	Min 37psi – Max 100psi (2.60 - 7.03kg/cm ²) with a minimum flow rate of 1 gpm (3.79 lpm)
Water Connection:	½" BSP - isolation valve is required within 3' (0.9m) of the installation
Integral Water Values:	All HydroTap systems are fitted with a Dual Check Valve and a 50psi (3.52kg/cm ²) Pressure Limiting Valve
Water Supply Requirements:	Potable drinking water supply
Optimal Total Dissolved Solids (TDS) Range:	TDS Min 50ppm – Max 150ppm
Integral Water Filter:	0.2 micron, 1 size - replace every 1,100 gallons / 4,163 liters or 12 months
Power Rating:	110-120V, 50-60Hz, 15 amp power supply with a NEMA 5-15 outlet
Dimensions (WxDxH):	11" x 16" x 13.1" / 280mm x 406mm x 333mm
Minimum Air Gap:	Minimum of 2" / 50mm clearance on left and right side and 8" / 200mm above
Minimum Cabinet Size:	18" wide x 15" deep / 457mm wide x 381mm deep
Maximum Hose Connection Length	3' / 0.9m (tap to command center)
Minimum Distance Needed for Installation	15" / 381mm (interior wall to garbage disposal)
Dry Weight:	66lbs / 30kg
Product Approvals:	IAPMO - NSF/ANSI 372, 42, 53, CSA B483.1, ASSE 1087; cUL; CEC
Warranty:	3 years
Compatible CO₂ Cylinder:	Zip Water 1.5lb CO ₂ or 5lb CO ₂ (if space allows) with CGA-320 fitting
CO₂ Operating Pressure:	Min 39psi - Max 44psi / Min 2.74 - Max 3.09kg/cm ²

HydroTap 120V CS G5 Command Center

Product Spec Sheet



Installation Requirements

Installation and connection of your HydroTap must be carried out by a qualified person, observing all local, state, & federal regulations. You will require suitable 110 -120V 50-60Hz, 15 amp power supply with a NEMA 5-15 electrical outlet within 5' 9" (1.75m) of the product.

The HydroTap is a pump-driven system so the installation of the Tap must be within 3' (0.9m) of the base command center. The HydroTap is an air-cooled system so discrete cabinetry cut-outs are required for ventilation. Installation on most countertops is straightforward however, some stone countertops may require a specialized cutting service.

If using a drip tray (font) accessory, suitable drainage to a trapped waste is required within 3' (0.9m) of the installation. If you live in an area with hard water (more than 150ppm), we recommend installation of a scale filtration kit or a water softener. Sufficient space and clearance to install the HydroTap as detailed in the product installation guidelines is required.

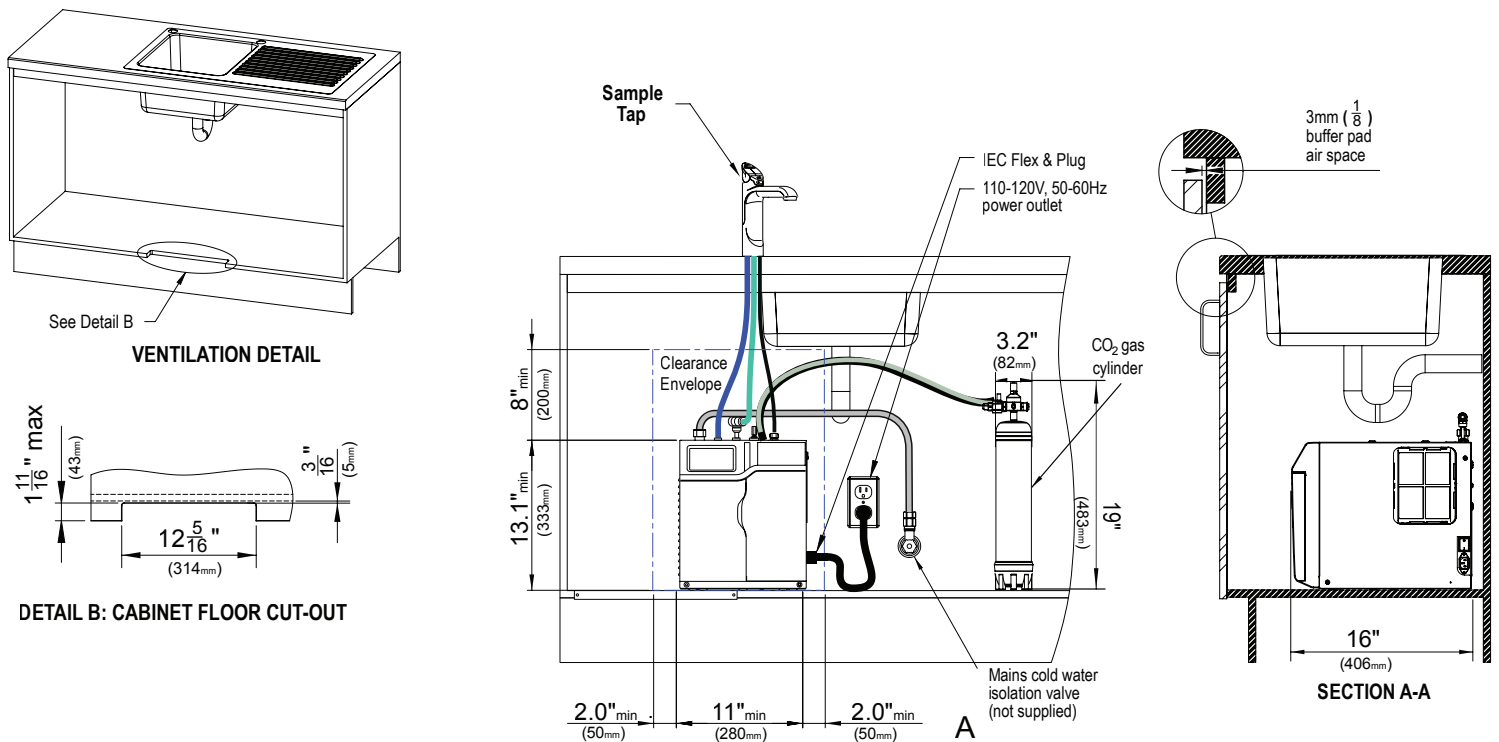

Scan QR code to view installation guide.